

Super Audio CD Transport

Monoblock D/A Converter

EGOTERIC

Grandioso P1X SE
Super Audio CD Transport

Grandioso D1X SE
Monoblock D/A Converter



The SE logo is centered in the upper half of the image. It consists of the letters "SE" in a bold, sans-serif font, enclosed within a white square.

Since its inception in 1987, Esoteric has been at the forefront of innovation as a high-end audio brand from Japan, continually pushing the boundaries of high quality sound reproduction. The Esoteric brand is known for its outstanding acoustic engineering that has sustained its reputation and prestige, its massive investment without regard to cost, its "museum quality" craftsmanship, and its beautiful designs worthy of music reproduction. "Grandioso" is the top model in each product category that has reached the highest level of quality defined by the brand.

In classical music, a phrase that indicates how a piece of music should be played is called a conception motto. For example, "cantabile" (as if singing), "legato" (smoothly), and so on. A flagship model should have the dignity and stature of a top-of-the-line product. We named it "grandioso" (grand, majestic, dignified), which we likened to the motto of classical music. Grandioso has brought a number of highly original innovations to the world of high-end audio, including the legendary VRDS-ATLAS Super Audio CD transport mechanism, the Master Sound Discrete DAC and the Master Sound Discrete Clock, which consist of unique discrete circuits.

Finally, three SE models are now available with new discrete clock technology and improved analog circuitry in the DAC. We are proud of our brand and always strive for the best sound.

The SE model we are releasing this time reflects every conceivable technological accumulation from the time the original model was launched to the present. Enjoy the enhanced presence, dynamics, and beautifully organic and musical textures of the three new SE models.

VRDS ATLAS

An Unprecedented Transport Mechanism That Invites You to the Furthest Reaches of Sound.



VRDS Technology

VRDS (Vibration-Free Rigid Disc-Clamping System) is Esoteric's unique CD/Super Audio CD transport technology, which has been specially designed to clamp the disc to a same-diameter turntable in order to eliminate the disc's rotational vibration, as well as any extraneous vibration emanating from the mechanism itself. It also corrects any warpage of the disc dramatically improving the accuracy of both the optical pickup and the disc pit layer's corresponding optical axis while also minimizing servo current. This all adds up to dramatically reduced disc read error for exceptional audio quality.

From NEO to ATLAS

It has been 16 years since the VRDS-NEO Super Audio CD transport mechanism first debuted in 2003. Improving on the NEO transport posed a difficult challenge, as it had long been praised as offering the highest audio reproduction performance in the industry. However, the design was totally reengineered from the ground up, resulting in a completely new platform that boasts unparalleled levels of structural refinement and audio fidelity.

The Highest Rigidity and Heaviest Construction in the History of VRDS

ATLAS boasts the highest rigidity and weight in the history of VRDS mechanisms. With its larger new SS400 steel side panels and bridge, the ATLAS is 27% heavier (6.6kg mechanism unit, 13.5kg including base) than the NEO, achieving both exceptional rigidity and impressive tone. It also dampens any and all vibration that might adversely affect audio quality. The turntable is machined from solid duralumin for excellent audio quality, and its spindle features a newly designed thrust bearing system. This friction-free one-point spindle support system ensures smooth, noiseless turntable rotation.

Wide & Low Center-of-Gravity Design

One of the keys to achieving the quietest mechanism in VRDS history is mechanical grounding technology that efficiently dampens vibration. By adopting a wide and low profile for the mechanism's design, the entire construction now features a low center of gravity. The turntable's drive system has also been refined and its motor moved to below the turntable from its previous position above the bridge, thus shortening the route for grounding vibration and greatly reducing mechanical noise.

Elegant Tray Mechanism Operation

The tray's form has been designed for the least possible resonance by minimizing hollowing, and boasts exceptionally smooth opening and closing operation with very little play. The use of special vibration-damping elastomer resin also further minimizes tray resonance during music playback.



ESOTERIC

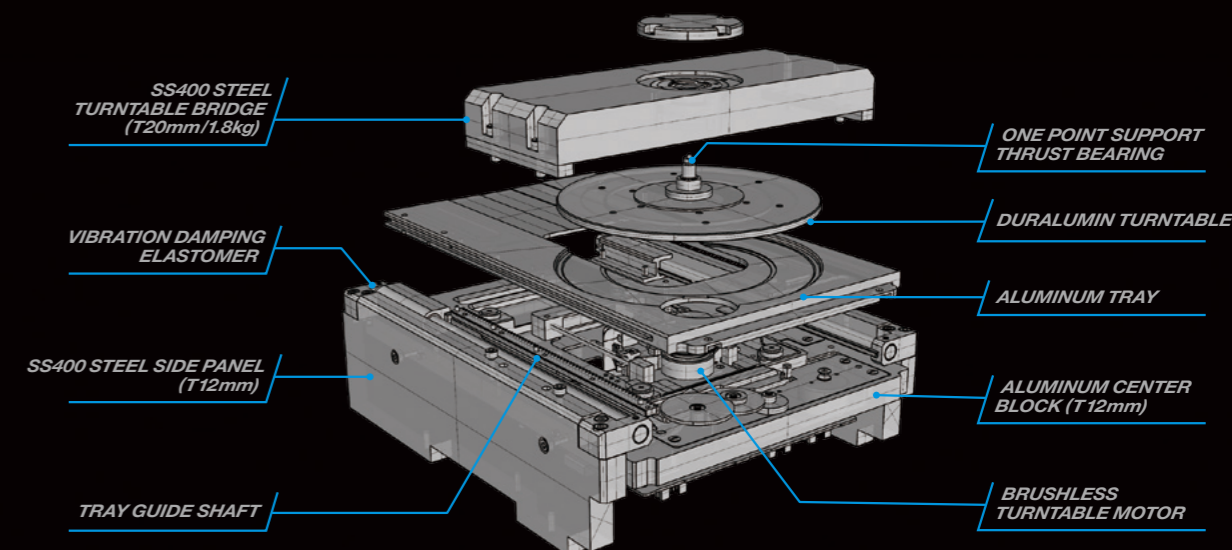

Grandioso P1X SE

Super Audio CD Transport

Esoteric's Premier Super Audio CD Transport, with Separate Power Supply Unit



ES-Link5 Digital Transmission (P1X SE / D1X SE)

Esoteric's own ES-Link digital interface utilizes HDMI cables for signal transmission. With the introduction of the P1X SE / D1X SE, ES-Link has been further upgraded to Ver. 5 and supports an even wider range of superior sound quality formats (Max. 22.5MHz DSD and 768kHz/48-bit PCM). HDMI's multi-conductor structure permits full balance transmission of audio data and LR clock and bit clock signals.

This differs from regular digital transmission as signal modulation is not required on the sender side and demodulation processing is not required on the receiver side, thus dramatically reducing digital processing loads on the DAC side and enabling ideal digital transmission.

Dual-Chassis Construction with Separate Power Supply

The P1X SE's power supply, as a fundamental source of vibration, has from its very first iteration been designed and constructed as a separate yet integral unit in order to achieve the quietest possible disc read characteristics and higher audio quality.



Power Supply Unit

Four Independent Toroidal Power Supply Transformers

The power supply incorporates a total of four independent toroidal transformers, which provide each circuit with a clean and powerful supply of electricity.

Low-Feedback DC Regulators (P1X SE / D1X SE)

Both the P1X SE and D1X SE feature low-feedback discrete DC regulators. The reduction in feedback level helps achieve a vibrantly energetic sound that seemingly overflows with a sensation of openness.

EDLC Super Capacitors (P1X SE / D1X SE)

Both the P1X SE and D1X SE include EDLC* super capacitors throughout their power supply circuitry. The P1X utilizes a total of 38 EDLCs (with a combined capacity of 1,400,00 μ F or 1.4F), while the D1X features a total of 50 EDLCs (for a combined capacity of 1,300,000 μ F/1.3F) for the pair. Through this maximization of power supply capacity, remarkable improvements in low-range resolution and audio quality have been achieved.

* EDLC (Electric Double-Layer Capacitor): Developed as next-generation power devices for the electric vehicle industry, these capacitors are attracting wider attention as cutting-edge technology due to their exceptionally high capacitance.

Multilayer Chassis (P1X SE / D1X SE)

Special care was also taken in the chassis construction of each unit, with a rigid, heavy-duty, thick aluminum panel enclosure to ensure thorough vibration control. The bottom chassis, to which each circuit component is attached, adopts a multi-layer structure using multiple steel plates. The power transformer and other components are fixed on separate layers and placed in a three-dimensional arrangement to prevent mutual interference between each component. Esoteric's original pinpoint foot (patents JP 4075477 and JP 3778108) has a gap between the foot itself and the chassis in the SE edition and is fixed by the weight of the chassis when placed, a new structure that avoids the concentration of stress that occurs when the foot is screwed to a large bottom plate, aiming for a more open sound.

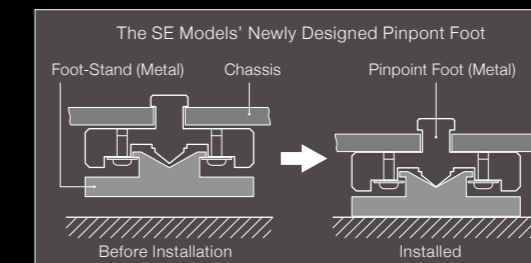

Semi Floating Top Panel (P1X SE / D1X SE)

The enclosure's top panel utilizes a screwless semi-floating structure that further contributes to an open and expansive sound.



Double-Faced Remote with Aluminum Fascia (RC-1333)

Master Sound Discrete DAC

Bringing Out All the Dynamics and Energy of the Original Master Recordings

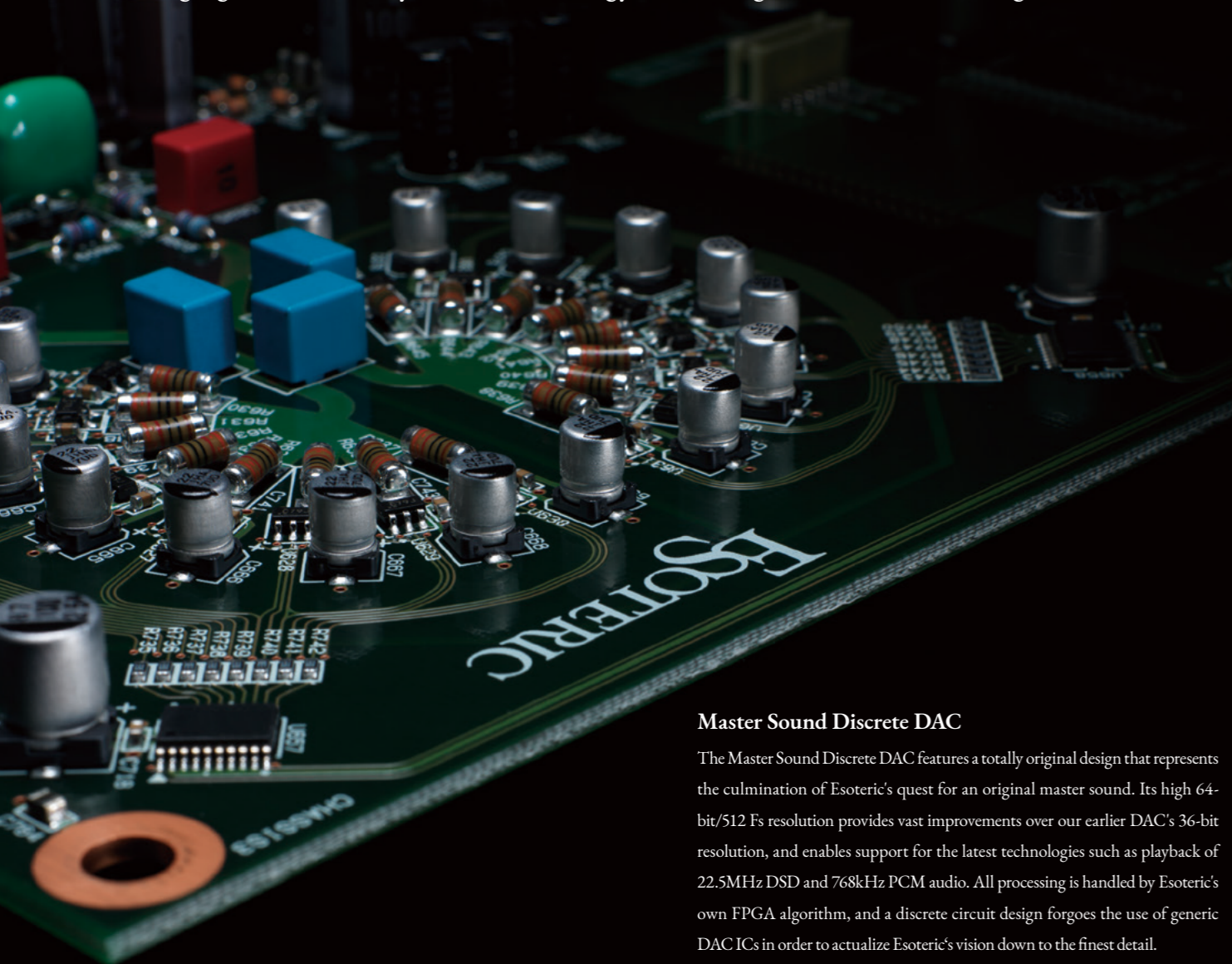

High 64-Bit/512 Fs Resolution

How close can digital come to analog? With Esoteric's Master Sound Discrete DAC, this question becomes a thing of the past. The Master Sound Discrete DAC's 64-bit/512 Fs resolution is the highest in Esoteric history, reducing digital rounding error to an absolute minimum in order to enable the faithful reproduction of the subtlest of textures.

Support for DSD 22.5 MHz DSD and 768 kHz PCM

The Master Sound Discrete DAC easily supports a broad range of formats, and can provide native playback of high resolution DSD master files. This impressive performance is merely one of its superlative attractions.

Our Aim Was to Faithfully Reproduce All the Vibrancy and Energy of Music.

64-bit/512Fs resolution and overwhelming performance. However, the true essence of this DAC cannot be discussed merely in terms of its specifications. The fundamental goal in the development of the Master Sound Discrete DAC was to achieve an accurate, full-bodied reproduction of all the vibrancy and energy of music. Music is infused with all the passion that a performer brings to a passage, with instantaneous and explosive energy. We wondered if it was possible to use higher-grade parts than integrated chips, as well as more luxurious materials, to create a more powerful DAC that could deliver a superlative analog signal. This idea led us to the discrete DAC. Esoteric's top engineering team painstakingly invested their very pride into realizing this complete, full-bodied sound.

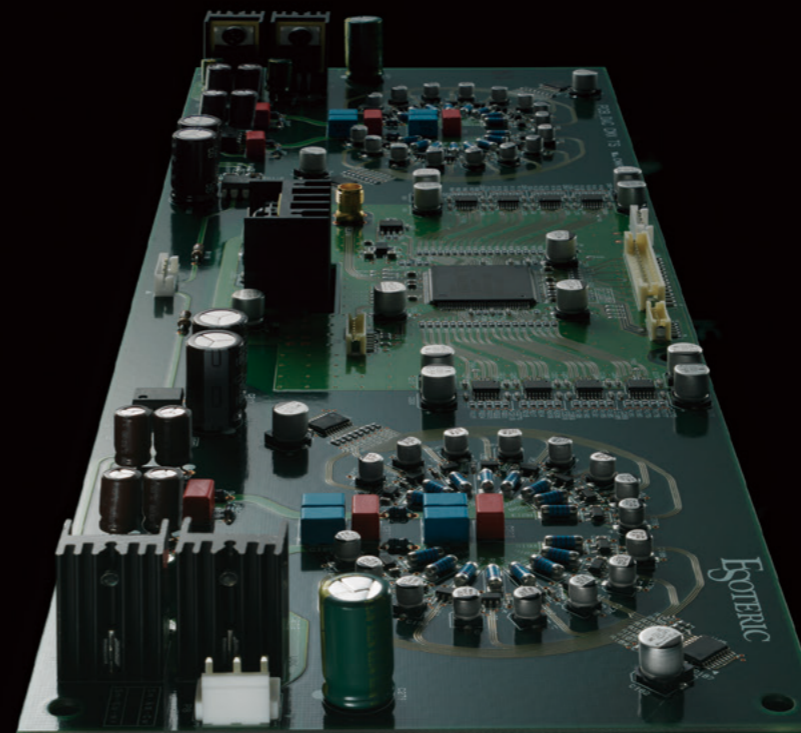

Upgraded with IDM-01 and Other Quality Parts

In the new SE model, the discrete parts of the analog circuitry on the DAC board have been refreshed for even better sound quality. The amplifier element is the original "Integrated Discrete-Amplifier Module IDM-01". The materials, circuit patterns, and layout have been carefully studied by Esoteric's engineers as if designing an amplifier with a discrete configuration, and the extremely short signal path that takes advantage of integrated circuits amplifies the vibrancy of music in a dynamic and subtle way. The IDM-01 and other analog parts, such as analog filter resistors and capacitors, have been carefully selected to achieve a more vivid live sound, improved audible dynamics, and a more organic texture.

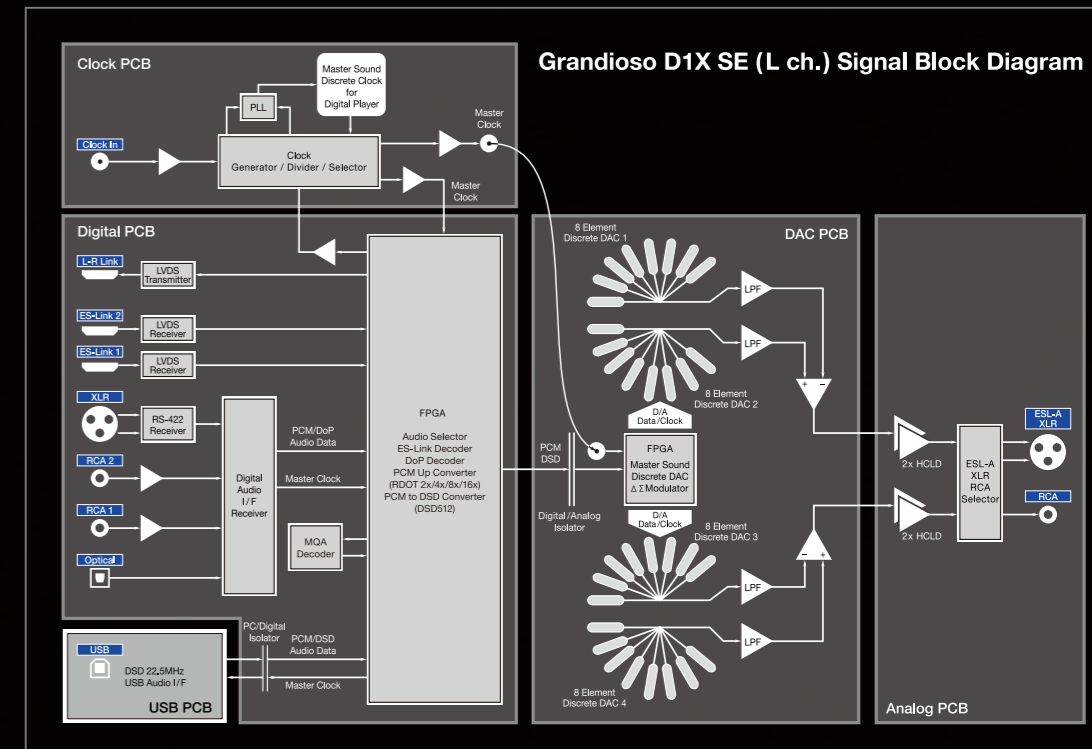
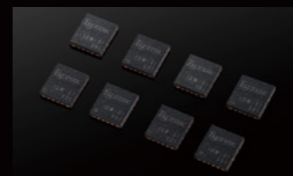

Luxurious Materials and Powerful Electrical Current Output

Featuring four DAC circuits per channel, their eight circuit elements are arranged in a semi-circle for equidistant signal transmission within each DAC. This total of 32 circuit elements are arranged in two circles that present a luxurious structure with all constituent components, including resistors, logic ICs, and power supplies, separated for all 32 of the circuits. Since each of these 32 circuits utilizes an independent power supply circuit, the music's full burst of energy can be output in its purest form. Furthermore, by selecting the same sort of ultra-high precision resistors used in measuring instruments, the DAC can perform high-speed digital arithmetic processing with greater accuracy.

Advanced Quality Control

With a discrete DAC, where component tolerances are directly linked to arithmetic precision, highly advanced quality control is also required for the manufacture of electronic circuit boards. Esoteric's own in-house factory boasts some of the world's leading board mounting technologies, such as soldering performed in an oxygen-free furnace, which is located in a clean room featuring the same level of cleanliness found in a hospital operating room. Technologies cultivated in the production of electronic circuit boards for audio, medical, aerospace, and defense industries support the high production quality of the Master Sound Discrete DAC.



Lower Section



Upper Section

Monoblock DAC

Setting its sights on achieving the highest levels of D/A conversion capability, Esoteric created the world's first monoblock D/A converter in 2004 with the D-01. The latest in this lineage of flagship D/A converters is the Grandioso D1X SE. Brushed up and liberally infused with new technologies, the D1X SE lets you fully enjoy the excellent channel separation of a dual monaural configuration coupled with truly stereophonic sound.

Esoteric-HCLD Output Buffer*

A fundamental element of audio quality, the Esoteric-HCLD output buffer amp is mounted on a separate board from the D/A converter, and its circuits have been upgraded to double the scale of the original Grandioso D1. As an indicator of its response speed, the buffer amp's main components boast an astoundingly high slew rate of 2,000V/ μ s. This buffer amp also features a four circuit parallel configuration for RCA output, and an extravagant configuration of two hot and cold circuits each for balanced XLR output. This enables the D1X to approach the very limits of powerful current-mode transmission and speed, which are the most important elements of an analog output circuit, and help reproduce the full reality of music with breathtaking dynamic range and clarity.

*HCLD: High Current Line Driver

ES-Link Analog for Current Transmission of the Highest Audio Quality

In addition to its XLR and RCA line connections to the amplifier, the D1X SE has also been equipped with Esoteric's own ES-Link Analog transmission system. Current-mode signal transmission is less susceptible to the effects of signal route impedance, thus enabling more powerful signal transmission. When connected to supported devices, ES-Link Analog offers an ideal transmission system for maximizing system potential.

Complete Isolation of Digital Circuits and Analog Circuits

All analog circuits are electrically isolated from the digital circuits, and separate power supplies are used for the digital and analog circuits. Each channel features two large and powerful toroidal power supply transformers, which provide a steady supply of clean power to each corresponding circuit block.

D/D Conversion

The D1X SE features the ability to upconvert a PCM digital signal up to 2, 4, 8 or 16 times higher sampling frequency (Max.768kHz). It also features a PCM-to-DSD conversion function (up to 22.5MHz), and a DSD digital filter that can be freely switched on or off.

USB Audio Interface Supports 22.5MHz DSD, 768kHz/32-Bit PCM, and Asynchronous Transmission

The D1X SE also includes a USB terminal for connection to a computer or network transport, enabling playback of studio master quality audio sources.

Master Sound Discrete Clock

for Digital Player

(P1X SE / D1X SE)

It is no exaggeration to say that the clock circuitry is the biggest key to high sound quality in digital music reproduction. For its flagship master clock generator Grandioso G1X, Esoteric has perfected its own in-house manufactured OCXO clock module, the Master Sound Discrete Clock. The G1X's unique discrete circuitry has been highly acclaimed for its superior musical expressiveness, creating a buzz in the world of high-end audio that has traditionally been described only in terms of technical specifications.

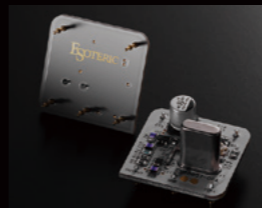

The "Master Sound Discrete Clock for Digital Player" used in the P1X SE/D1X SE applies the basic design concept of G1X's in-house manufactured OCXO module to the internal clock of the digital player models. The unique circuit design using carefully selected discrete components, such as a large crystal oscillator, achieves high sound quality that reflects Esoteric's philosophy in every detail, which cannot be achieved with an off-the-shelf clock module. The P1X SE/D1X SE can also be connected to the Grandioso G1X external master clock generator to improve sound quality by synchronizing the internal circuitry to an even more accurate 10 MHz clock.

Grandioso D1X SE
Monoblock D/A Converter

The Ultimate Esoteric Monoblock DAC for the Ultimate in Stereo Playback.



Grandioso P1X SE *Super Audio CD Transport*

Key Features

- "VRDS-ATLAS" Super Audio CD transport mechanism
- "ES-Link5" ultra-wide range digital transmission
- Two chassis configuration (main unit + power supply unit)
- "Master Sound Discrete Clock for Digital Player" – in-house developed discrete clock module **SE**
- Clock sync function
- Low-feedback discrete DC regulators
- Four independent toroidal power supply transformers
- Semi-floating top panel
- Redesigned pinpoint foot **SE**

SE : New features of the SE model



Specifications

Playable Disc Types:	Super Audio CD, CD, CD-R, CD-RW
Digital Audio Outputs:	ES-Link x 1, XLR x 2*, RCA x 1
Clock Input:	BNC x 1 (10MHz ±10ppm, 50Ω, Sine Wave 0.5 to 1.0Vrms)
Power:	120V AC 60Hz, 220-240V AC 50Hz
Power Consumption:	20W
Overall Dimensions (WxHxD):	445 x 162 x 449mm (Main Unit)
(Including Protrusions)	445 x 132 x 452mm (Power Supply Unit)
Weight:	29kg (Main Unit), 24kg (Power Supply Unit)



Double-face remote
RC-1333 included

* During Dual AES output, one connector each for left and right channels of a stereo pair.
Version-up service from the Grandioso P1X to the P1X SE is available.

- These products are available in two different power supply variations as shown in the chart above. Make sure that the voltage shown on the rear panel matches the AC line voltage in your area.
- The shape of the AC inlet and plug of the supplied power cord depends on the voltage rating and destination country.

Please note that not all models are available in every country. Design and specifications subject to change without notice.
©2023 Esoteric Company. All Rights Reserved. All text, images, graphics and other materials on this brochure are subject to the copyright and other intellectual property rights of Esoteric Company. These materials shall not directly or indirectly be published, reproduced, modified or distributed in any medium. Esoteric is a trademark of TEAC Corporation, registered in the U.S. and other countries. Grandioso is a trademark of TEAC Corporation. All other brand or product names are trademarks or registered trademarks of their respective holders.

ESOTERIC COMPANY

1-47, Ochiai, Tama-shi, Tokyo Japan 206-8530
<https://www.esoteric.jp/en>



Grandioso D1X SE *Monoblock D/A Converter*

Key Features

- "Master Sound Discrete DAC" – In-house developed FPGA, 64bit/512Fs Delta-Sigma modulator
- Up-graded DAC board with specially selected quality parts including IDM-01
- "ES-Link5" ultra-wide range digital transmission (DSD 22.5MHz, PCM 768kHz/48bit)
- "Esoteric-HCLD" output buffer amplifier (slew rate: 2,000V/μs)
- "ES-Link Analog" current signal transmission output
- "Master Sound Discrete Clock for Digital Player" – in-house developed discrete clock module **SE**
- Clock sync function
- Low-feedback discrete DC regulators
- Two independent toroidal power supply transformers/ch
- MQA decoder / up-convert function
- USB input (DSD 22.5MHz, PCM 768kHz/32bit, asynchronous transmission)
- Semi-floating top panel
- Redesigned pinpoint foot **SE**

SE : New features of the SE model



Specifications

Frequency Response:	5Hz to 30kHz (-3dB)
Total Harmonic Distortion:	0.0007% (1kHz)
S/N Ratio:	113dB
Analog Audio Outputs:	XLR/ESL-A x 1 (XLR = Impedance: 100Ω, Output Level: 5Vrms) RCA x 1 (Impedance: 47Ω, Output Level: 2.5Vrms)
Digital Audio Inputs:	ES-Link x 2, XLR x 1, RCA x 2, OPT x 1, USB x 1 (USB2.0)
Clock Inputs:	BNC x 1 (10MHz ±10ppm, 50Ω, Sine Wave 0.5 to 1.0Vrms)
Power:	120V AC 60Hz, 220-240V AC 50Hz
Power Consumption:	20W
Overall Dimensions (WxHxD):	445 x 132 x 448mm (Including Protrusions)
Weight:	23.1kg (L ch), 23.0kg (R ch)

Version-up service from the Grandioso D1X to the D1X SE is available.



Authorized Dealer